















Parts needed to assemble and mount the MULTIBO fastener set

- | | |
|----------------------------|---|
| Nut Fi 3 mm (O) |  |
| Top nut (N) |  |
| Locking washer (M) |  |
| Power connector (L) |  |
| Bottom nut (K) |  |
| Metal washer (J) |  |
| Top washer (I) |  |
| Bottom washer (H) |  |
| Hollow rod (G) |  |
| Top head (F) |  |
| Arm (E) |  |
| Bottom head (D) |  |
| Plastic insert (C) |  |
| Bottom power connector (B) |  |
| Bolt (A) |  |

Tools needed for mounting:

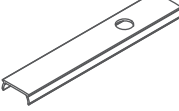
- allen wrench
- drill
- pliers

NOTE! A list of products corresponding with the selected accessories is available at www.klusdesign.eu/uk.

1. Drill a hole with a diameter of 10 mm in the extrusion. Connect the power cable from the power supply to the power connector (K).

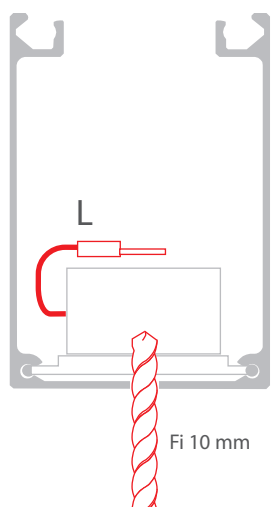

2. Insert the rod (G) into the hole in the profile. From the outside put on the bottom washer (H) and head (F). Inside, put on the top washer (I), metal washer (J) and bottom nut (K).

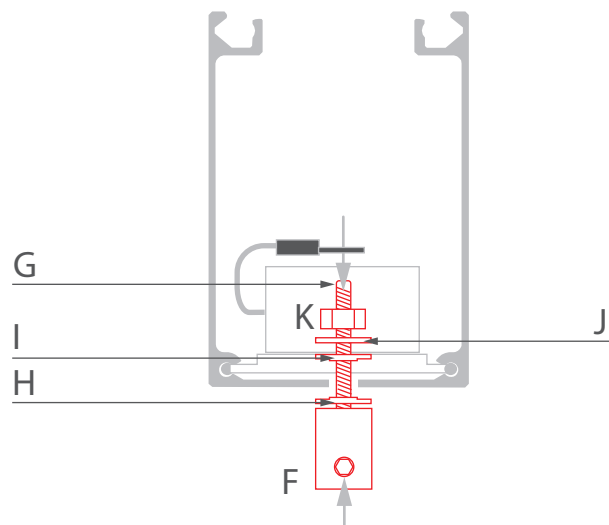

3. Put the power connector (L) on the hollow rod (G) and then on put the locking washer (M) and top nut (N).

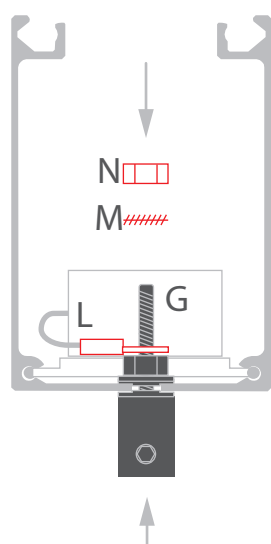

4. Insert the arm (E) into the light fixture, head and hollow rod. **NOTE!** The arm must not touch the aluminum slot of the BOX extrusion. Finally, tighten the bolt in the head with the Allen wrench and put on and tighten the nut Fi 3 mm (O).

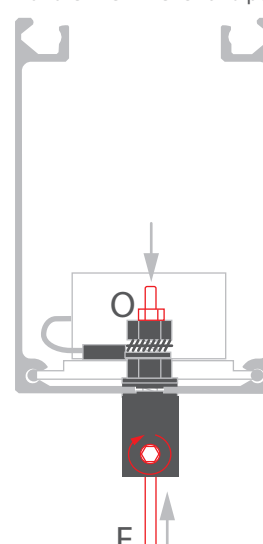

5. Connect the bottom power connector (B) to the LED cable in the fixture.

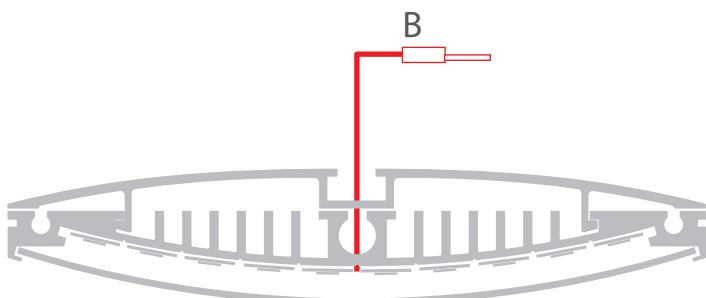

6. Fix the power connector to the insert (C) and head (D) with the nut (A).

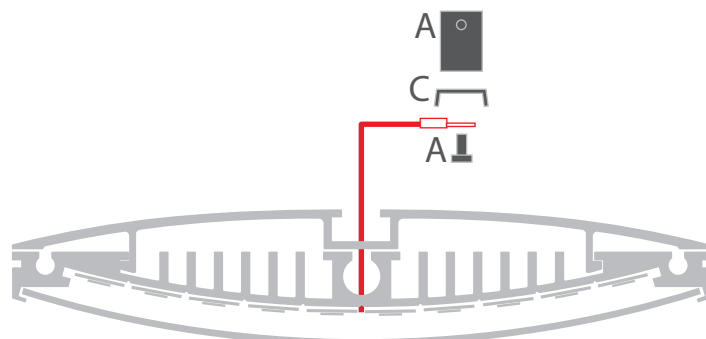

7. Insert the assembled head with the insert and the power connector into the channel of the lighting fixture. [Download the assembly instructions for MULTI-A and MULTI-B profiles](#) at klusdesign.com.

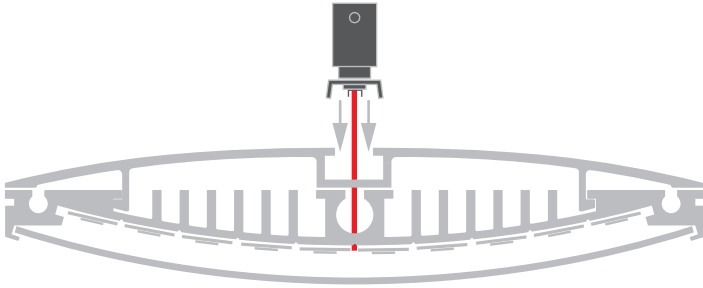

8. NOTE! Mount the fixture on the arms (E) by inserting them into the heads (D) and tightening the pressure screws in the heads with the Allen

